

FAB5URP

50's Retro style

Approx 16" 50's Retro Style
Mini Refrigerator,
Cream, Right hand hinge

EAN13: 8017709192969

Capacity 1.5 Cu. Ft.

Available with right and left hinge

Absorption cooling = ultra low noise level

Automatic defrost

LED Internal light

2 adjustable shelves

Door storage: 1 balcony shelf, 1 bottle shelf

ELECTRICAL CONNECTION:

Voltage: 120V 60Hz

Current: 1.0 Amps

Dimensions:

H x W x D) 28 1/8" x 15 15/16" x 22 1/16"

Gross Weight: 65lbs.

Net Weight: 51.2 lbs.





FAB5URP

50's Retro style

fridge
free standing
50's style
cream

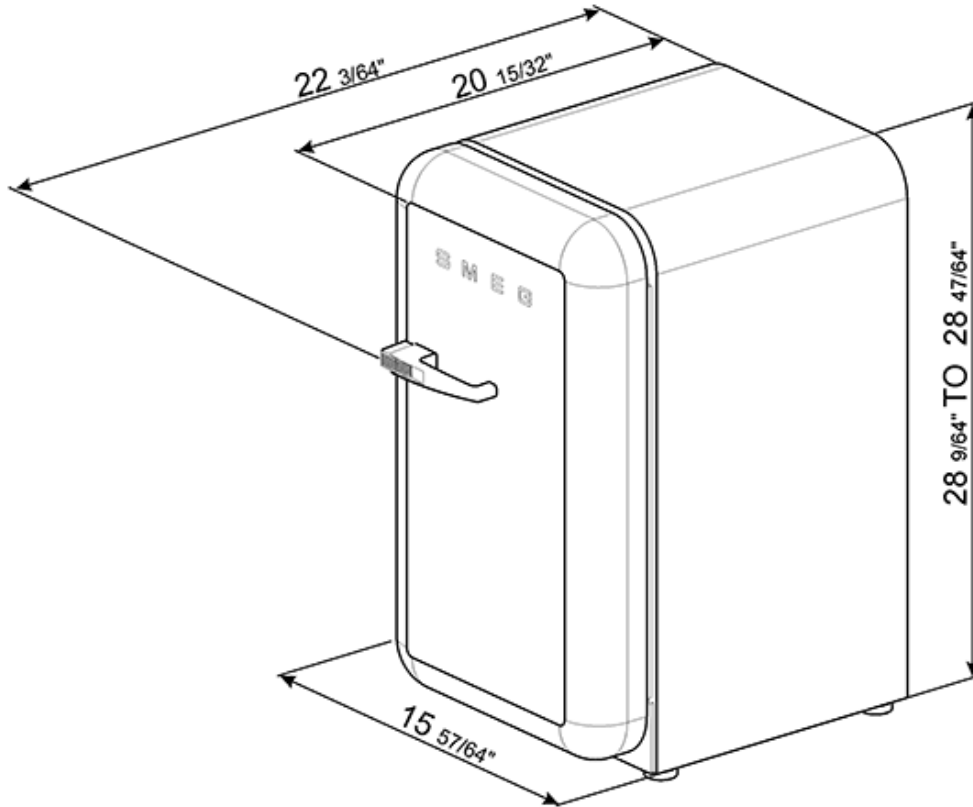

SMEG U.S.A. INC.
A&D BUILDING
150 EAST 58th STREET, 7th FLOOR
NEW YORK, NY, 10155
Tel. +1 212 265 5378
Fax +1 212 265 5945